

BRISTAN

Installation Instructions and User Guide

Descent Tap Range

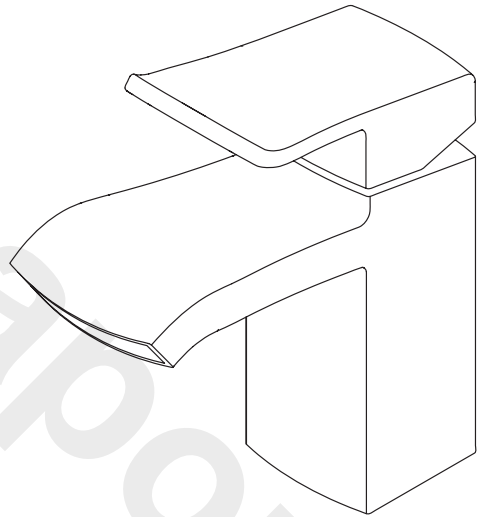

Models Covered:

DSC BAS C, DSC BF C, DSC BSM C,
DSC 1HBF C, DSC FSBSM C

Please keep this booklet for future reference.

Installer, when you have read these instructions please ensure you leave them with the user.

Contents

Thank you for choosing Bristan.

These fitting instructions have been created to give you all of the information you need for a safe and successful installation, so please read them thoroughly and retain for future reference.

If you need any further help, please do not hesitate to give us a call on 0330 026 6273.

Contents

- Important Safety Information **3**
- General Information **4**
- Specifications **4**
- Dimensions (mm) **5-7**
- Installation Requirements **8**
- Installation **9-11**
- Maintenance **12-13**
- Troubleshooting **13**
- Guarantee **14**
- Notes **15**

Important Safety Information

All products manufactured and supplied by the manufacturer are safe to use provided that they are installed, operated and receive regular maintenance in accordance with these instructions.

If you are in any doubt about your ability to install this product safely you must employ the services of an experienced qualified plumber.

This product needs to be installed in accordance with, and meet the requirements of the Water Supply (Water Fittings) Regulations 1999 and current by-laws. For full Installation Requirements & Notes (IRN) please visit wras.co.uk/directory.

Remove all packaging and check the components for damage before starting installation. Before starting any installation please consider the following:



Prior to drilling into walls, check that there are no hidden electrical wires, cables or water supply pipes. This can be checked with the aid of an electronic detector.

If power tools are used do not forget to:

- Wear eye protection
- Unplug equipment after use

Isolation valves must be fitted to the inlet water supplies to ensure ease of future maintenance.

Before installing this product the water supply must be thoroughly flushed in order to remove any swarf, solder etc.

This product must not be modified in any way as this will invalidate the guarantee.

Full access must be made available for future maintenance/servicing purposes.

If in doubt, contact a registered plumber or your Local Water Authority or the Secretary of the Institute of Plumbing, address as follows:-

The Institute of Plumbing,
64 Station Lane,
Hornchurch,
Essex,
RM12 6NB, Tel: 01708 472791

General Information

This product has been designed to comply with BS EN 200 for combination taps to be used within systems designed to BS 6700.

BS 6700 recommends the temperature of stored water should never exceed 65°C. A stored water temperature of 60°C is considered sufficient to meet all normal requirements and will minimise the build up of lime scale in hard water areas.

If installing this product on a low pressure (tank fed) system please see specification table below to determine the minimum distance required from underside of the cold water tank to the outlet.

These taps and mixers should be installed in compliance with the Water Regulations. Where the supplies are unbalanced, i.e. Hot water from cylinder tank/cold from the mains, approved check valves must be fitted in the supply pipes.

For further details contact your Local Water Authority.

Specifications

Product Code	Working Pressures		Inlet	Minimum distance from cold water tank to outlet (metres)
	Min	Max		
DSC BAS C	0.2	5.0	M10 15mm Compression Flexible Tails	2
DSC BF C	0.2	5.0	3/4" BSP Threaded Tail	2
DSC BSM C	0.3	5.0	3/4" BSP Threaded Tail	3
DSC 1HBF C	1.0	5.0	M12 15mm Compression Flexible Tails	10
DSC FSBSM C	1.5	5.0	M12 15mm Compression Flexible Tails	15

Maximum static pressure: 10.0 bar

System Requirements:

Gravity fed hot & cold (Equal pressures)

Gravity fed hot & cold (Differential pressure, maximum ratio 5:1)

Unvented systems

Instantaneous water heater (Combination boiler)

Dimensions (mm)

Basin Mixer

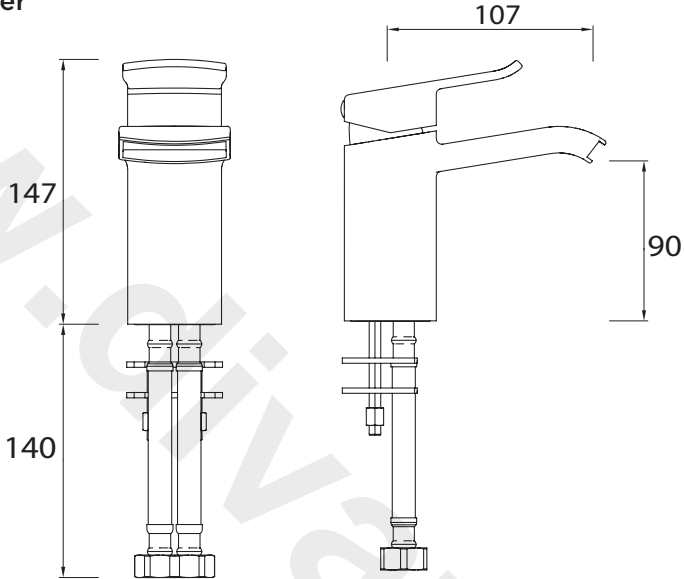

Bath Filler

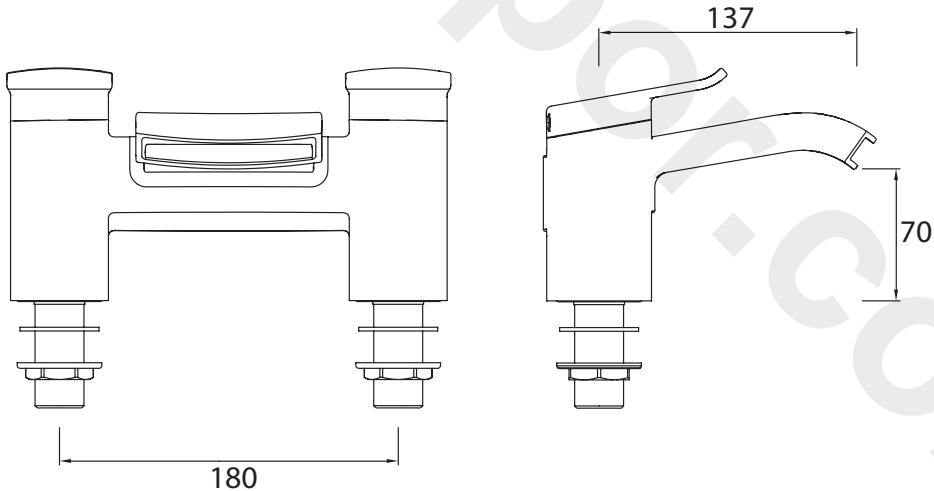

Dimensions are approximate and in millimetres.

Dimensions (mm)

Bath Shower Mixer

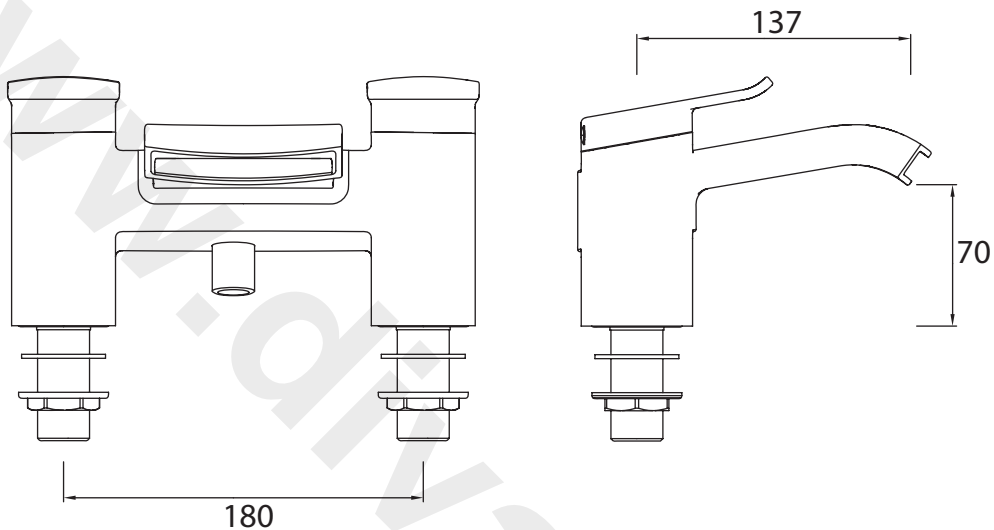

1 Hole Bath Filler

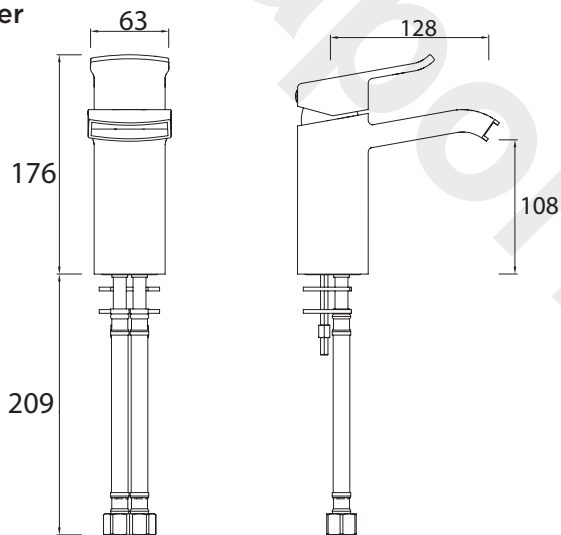

Dimensions are approximate and in millimetres.

Dimensions (mm)

Floor Standing Bath Shower Mixer

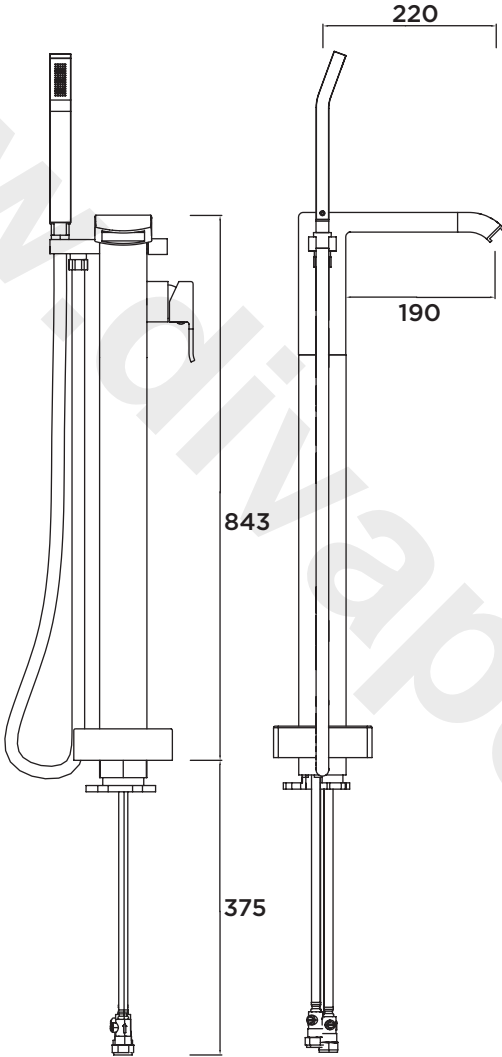

Dimensions are approximate and in millimetres.

Installation Requirements

Flexible Connecting Pipes

Care must be taken when connecting the flexible connection pipes to the household pipework to ensure they do not bend sharply and kink or twist.

See below for recommended ways to fit the flexible connecting pipes.

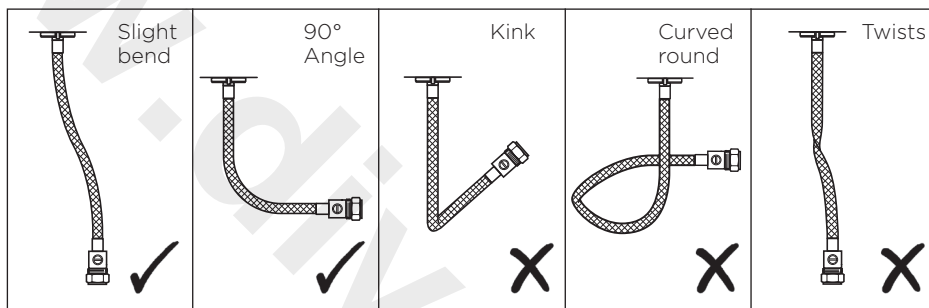

 **Important:** Failure to follow these guidelines may result in poor performance and damage to the flexible connecting pipes.

 **Important:** Full access must be made available on installation for future maintenance/ servicing purposes.

Installation

Basin Mixer / 1 Hole Bath Filler

1. Screw the flexi tails into the bottom of the body by **hand only (DO NOT OVERTIGHTEN)**.

2. Feed the flexi tails through the hole in the basin / bath, ensuring the washer is fitted between the tap body and fixing surface to ensure a water tight seal.

3. Screw the fixing rods into the bottom of the tap body. Slide the 'C' shaped rubber washer and 'C' shaped metal washer onto the fixing rods up to the underside of the basin/bath.

4. To secure the tap body in place tighten the fixing nuts onto the fixing rods until they are fully tightened against the 'C' shaped metal washer. The fixing nuts can be tightened with a suitable spanner.

5. Connect the flexible tails to the hot and cold water supplies.

6. Turn on both water supplies, operate the handle in both directions, letting the water flow for a few minutes to flush through the system.

7. Fit the clicker waste (for **basin mixer only**) ensuring the rubber washer is fitted between the basin and the waste. Place the other rubber washer under the basin and secure by tightening the backnut, in order to fill the basin, the button in the middle of the waste needs to be pressed down. To release the water, press the button again.

8. Check all joints and connections for any leaks.

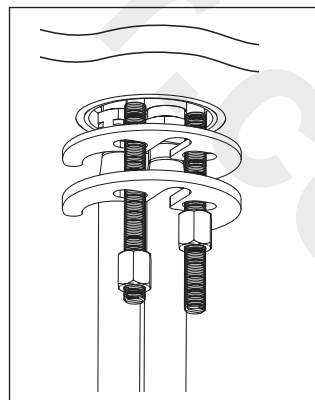
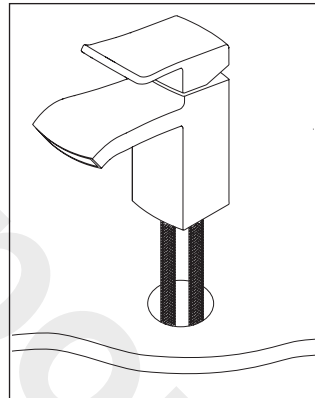
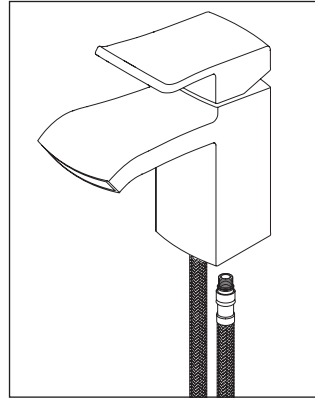

Installation

Bath Filler and Bath Shower Mixer

1. Fit the tap body to the bath ensuring that the washers are fitted between the body and the bath to create a water tight seal.

2. Secure the body to the bath using the washers and metal backnut. Tighten the backnuts onto the threaded tails. A suitable spanner may be required to fully tighten the backnuts.

3. Connect the hot and cold water supplies to the threaded tails using a $\frac{3}{4}$ " BSP connector (not supplied).

4. **Bath Shower Mixer only** - fit the shower hose to the hose outlet using the small sealing washer, and the handset to the hose using the small washer.

⚠ Important: Prior to the drilling into walls, check there no hidden electrical wires, cables or water supply pipes with the aid of an electronic detector.

If you use power tools do not forget to:

- Wear eye protection
- Unplug equipment after use

Fit the wall bracket (not shown) to the wall using the fixings supplied, ensuring the handset and hose reaches it.

5. Turn on both water supplies and turn both handles to the on position, letting the water flow for a few minutes.

6. Check all joins and connections for any leaks.

7. To switch from bath to shower mode, pull the diverter knob up and turn, to revert back to bath filling mode push the diverter knob back down.

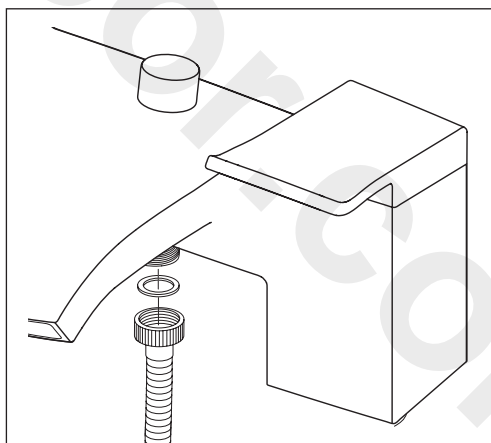
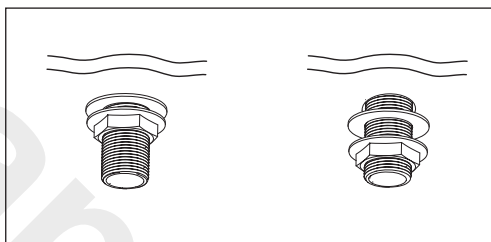
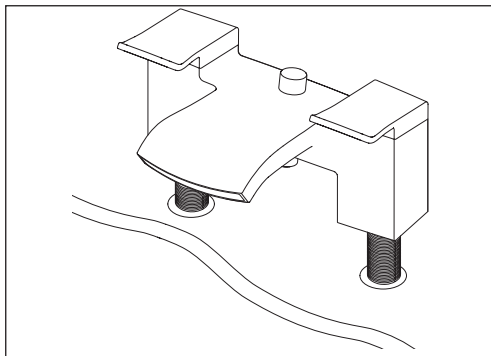

Installation

Floor Standing Bath Shower Mixer

1. Mark the fixing holes of the base onto the floor surface at the required position, also marking a central hole for the flexi tails to go through.

Note: If the bath shower mixer is to be fitted onto wooden floorboards, the boards must be reinforced with additional wooden batons due to the height and weight of the bath shower mixer. If the floorboards are not reinforced this may result in the mixer flexing slightly during operation.

2. Drill suitable holes for the fixings and the central hole.

3. Terminate suitable pipework for the water supplies under the floor and ensure the flexi tails will be able to connect once the bath shower mixer is fitted.

4. Slide the plinth along the mixer body and thread the flexi tails through the fixing base. Thread the flexi tails through the central hole and connect to the water supplies. The flexi tails are marked red for hot and blue for cold.

5. Secure the fixing base to the floor using the fixing supplied.

6. Screw the mixer body onto the fixing base and push the plinth down to cover the base.

7. Connect the hose to the hose outlet and fit the handset to the hose using the small washers.

8. Turn on both water supplies. Operate the handle in both directions, letting the water flow for a few minutes.

9. Check all joints and connections for any leaks, before finishing the floor work.

10. Operate the mixer in both, bath and shower mode. To switch from bath to shower mode, pull and then twist the diverter. To revert back to bath fill, turn the diverter back.

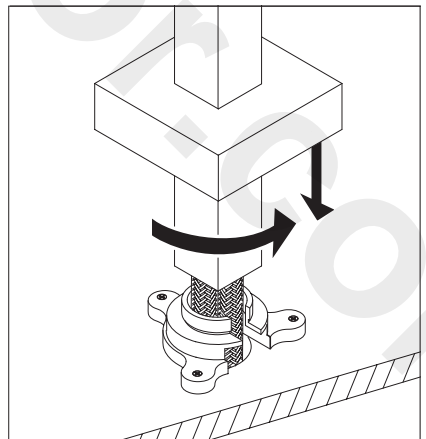
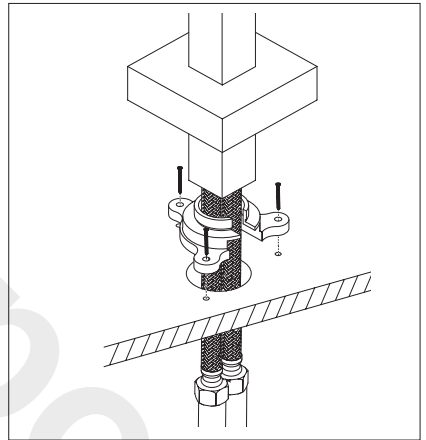
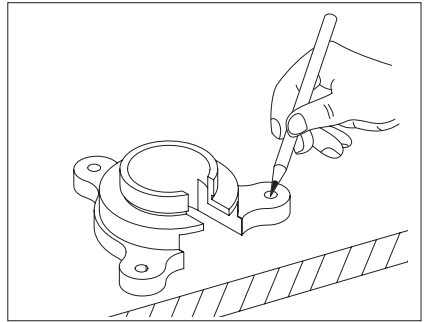

Maintenance

General Cleaning

Bristan products are made from premium materials, with hand polishing and electroplated finishes.

Your taps or shower should be regularly cleaned with warm water, a mild pH-neutral liquid soap, and polished with a soft cloth. Any residues from soap, toothpaste, shampoos and shower gels can cause blemishes if not rinsed off straight after use.

Household bleaches and cleaners contain harsh chemicals and may damage the surface finish. Avoid using abrasive cloths, scouring pads, scrub sponges, steel wool or anything similar.

Some surfaces such as nickel and pewter may be affected by the dye found in some cloths, so it is also important to avoid hanging cloths on spouts.

Cartridge/Valve Cleaning

Before carrying out any maintenance, turn off the both water supplies or close any isolating valves. Prise out the handle cap, loosen the grub screw using a 2.5mm hexagonal key and remove the handle.

Valve

Remove the spline adaptor. Using a suitable socket remove the valve. Wash the valve with clean running water and make sure that any debris has been removed. Lightly grease the seal (only use silicone grease), replace the valve, spline adaptor and handle. Tighten the grub screw and push fit the cap.

⚠ Important: Tighten the valve/retaining nut with the correct size spanner / socket and apply appropriate force/torque.

Do not overtighten.

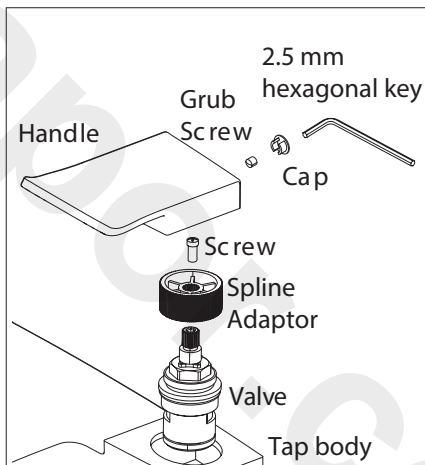

Maintenance

Cartridge

Unscrew the shroud and cartridge retaining nut and pull the cartridge out from the body. Clean the cartridge thoroughly under cold water to remove any build up of limescale or debris. Replace the cartridge into the body and tighten the retaining nut and shroud. Push the handle onto the cartridge and tighten the grub screw and push fit the cap.

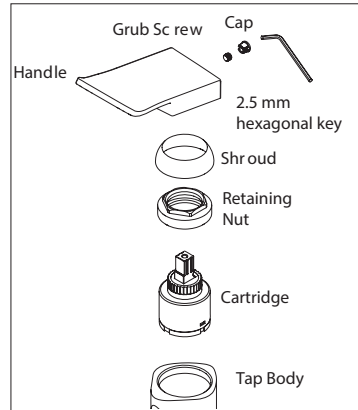

Troubleshooting

Symptom	Cause	Remedy
No flow or low flow rate	Partially closed isolation valve.	Open isolation valve.
	Instantaneous water heater cycles on and off as flow rate or pressure is too low.	Increase water flow rate or pressure through system to meet required minimum working pressure of tap.
	Head of water is below the minimum distance required.	Refer to 'Specifications' on page 5.
	Hot or cold water being drawn off elsewhere causing pressure changes or instantaneous boiler temperature changes.	Do not use other water outlets when using the taps.
	Airlock or partial blockage in the supply pipework.	Flush through pipework to ensure removal of debris and any airlocks.
Water dripping from taps	This is normal for a short time after using the taps.	This is caused by residual water tension, the build up of water in the tap body.
	If water continues to drip, possible build up of debris/limescale in ceramic disc valves.	Remove valves/cartridge and clean, refer to 'Maintenance' section before removing.
Taps do not turn on	Closed isolation valve.	Open isolation valve.
	Water supplies to the tap turned off.	Turn on both water supplies to the tap.

Need help? Give us a call on **0330 026 6273** and speak to one of our trained advisors. **13**

Guarantee

At Bristan, we want to make things as easy as possible for our customers. That's why we offer solid guarantees on all our products, effective from the date of purchase, to give you peace of mind.

To start your free guarantee simply scan the QR code and register your product.

Alternatively visit www.bristan.com/register to register your product via a computer.

For full guarantee terms and conditions visit www.bristan.com/guarantees.

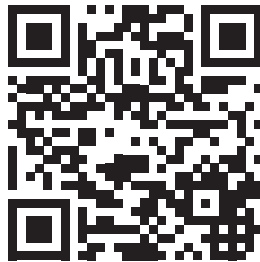

Notes

www.divapor.com

Issue: D2
Part Number: DSC BOOK 1

BRISTAN

Address

Birch Coppice Business Park

Dordon

Tamworth

Staffordshire

B78 1SG

Web: www.bristan.com

Email: enquire@bristan.com

A Masco Company